



ICON 200/160

NEW DECENTRALIZED HEAT RECOVERY UNIT



MANAGEMENT OF
THE PRODUCT ALSO
THROUGH THE APP



NEW BRUSHLESS
MOTOR



VOC SENSOR
INTEGRATED



INCREASED THE
HEAT EXCHANGE
SURFACE



4 ADJUSTABLE
SPEEDS



INCREASE OF THE
MAXIMUM AIRFLOW



CONSUMPTION
FROM 4 W



THERMAL EFFICIENCY
UP TO 93%



LESS CONCENTRATION OF
THE CARBON DIOXIDE
IN THE ENVIRONMENTS



MAXIMAL
QUIETNESS





**STANDARD INSTALLATION
FOR EVERY KIND OF
ENVIRONMENT**



**BUILT IN
VERSION FOR A
THINNER DESIGN**

STYLISTIC PURITY AND FUNCTIONALITY

Icon overcomes the pure aesthetic side and becomes a functional and interactive element of the room. With the standard and built in version you have the liberty of **choosing the best solution**. A slim solution to concentrate in few millimeters **high performances, functional and aesthetic**.

19°C

5°C

SO.ERRE

EXTRACT, RECOVER, INTAKE, SAVE

Icon 200/160 **ensures a controlled internal air exchange**, maintaining the energetic efficiency, reducing the dispersion of the heat, **improving the quality of the air** and contributing in a significant manner to the **energy saving** and to the maintenance of a comfortable living environment.

BRING THE SILENCE INTO YOUR HOME

Reduce the noise coming from the outside

The external unit, designed to reduce the noise from outside towards inside, is a key element to create a calm environment in the middle of noisy ones.

The employment of **acoustic filters and brushless motor** placed inside the product completes the system and helps to **limit considerably the sound interferences** coming from outside.

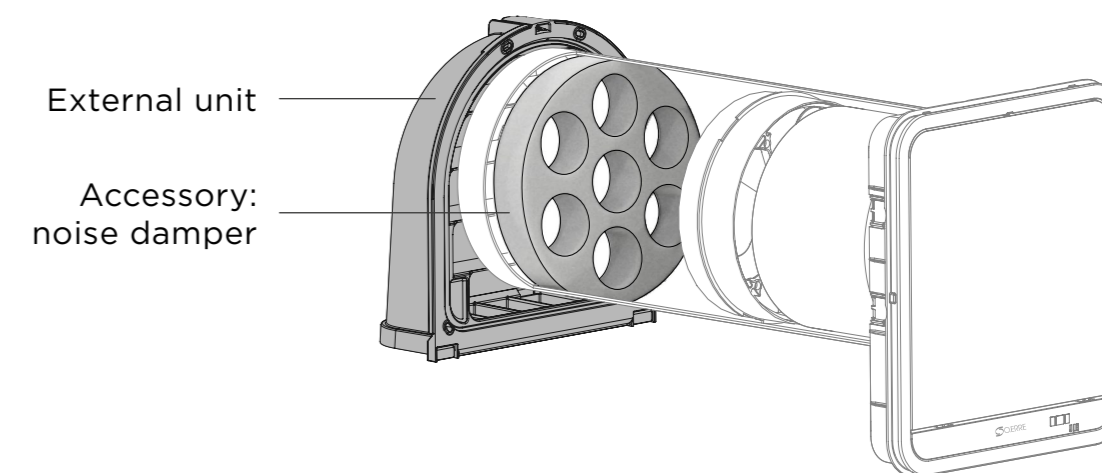

AVAILABLE FILTERS:

- 
 STANDARD
- 
 ISO
COARSE
30%
- 
 ISO
COARSE
45%
- 
 ISO
COARSE
60%
- 
 ePM10
50%

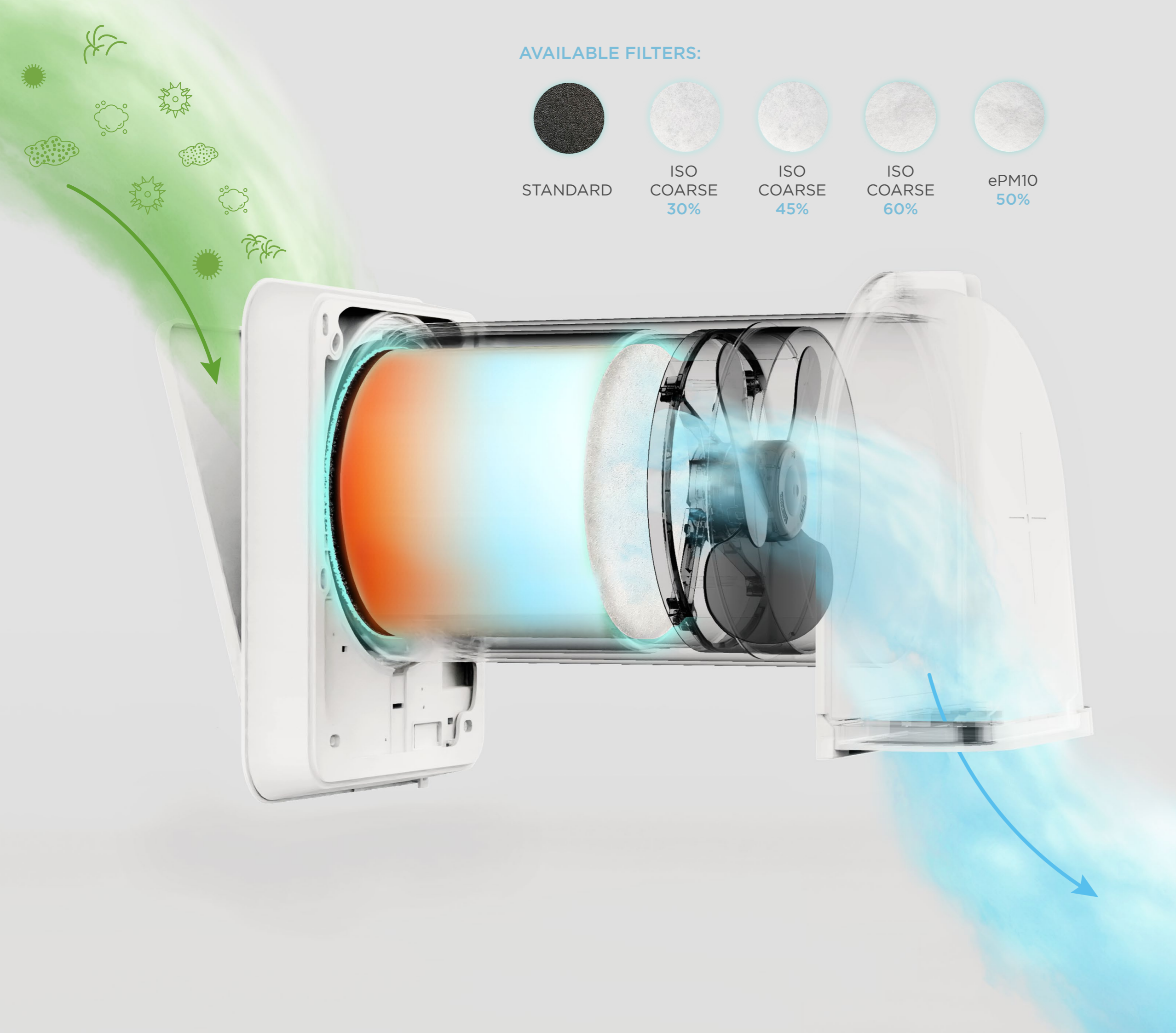

IMPROVE THE QUALITY OF AIR IN YOUR HOME

**More oxygen in the room
for a healthier life**

The mode of the reduction of the domestic pollution by means of filtration done by letting the **air passing through one or more filters**, which have the purpose of **holding the polluting substances**, preventing them to return in the airflow (like fur, hair, pollen, sand, dust in general).

PERFECT DIALOGUE

With the devices of the ICON family, O.ERRE starts a new range of solutions and connected systems, **designed to simplify every function of the house**. An evolved ecosystem is born and it amplifies the experience of living and elongates towards a more involving and multi-sensorial dimension. **Sensors* and actuators** connected, **facilitate every gesture** done within the domestic walls, combining practical information, comfort and automation.



* humidity, twilight, temperature and VOC sensors

THE NEW O.ERRE APP IS BORN

Capable of **controlling the installed products** within the house **in a simple and immediate manner**, even if you are away from home.



4 FUNCTIONS:

1 AUTOMATIC FUNCTION

Automatic functioning mode in heat recovery. The unit is managed by sensors.

2 SMART FUNCTION

The temperature and the quality of the external and internal air will be elaborated by an algorithm, studied by O.ERRE, which will automatically modify the functions of the device.

3 AWAY HOME FUNCTION

In case of exceeding the pre-set threshold of humidity, the product will automatically activate itself to lower the parameter below the safety threshold.

4 NIGHT FUNCTION

The function will automatically activate during the night hours, in order to grant an air exchange at maximal quietness, creating the ideal environment for night rest.

AIR
QUALITY
CONTROL

FILTER
STATUS

AIRFLOW
SPEED

HUMIDITY
CONTROL

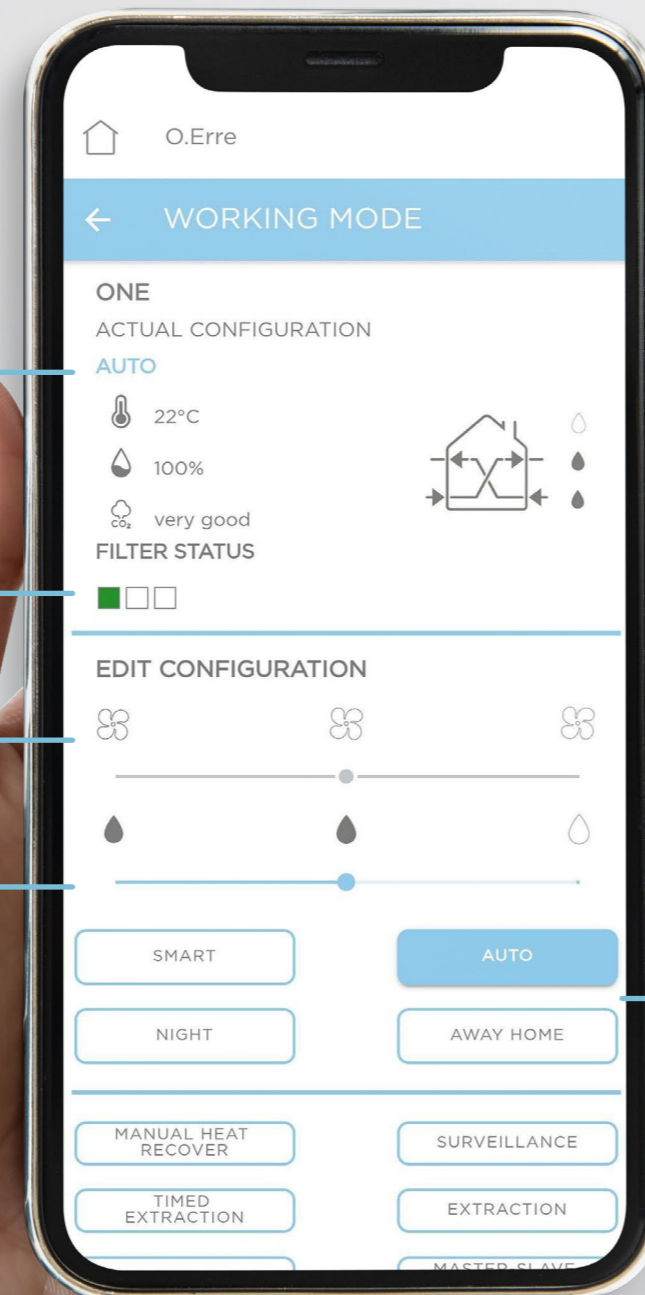



 S.O.ERRE

ICON 200/160



Visit our website

